

Scheda tecnica :

MLT 737-130 PS+



 **MANITOU**
HANDLING YOUR WORLD

Capacità		Metrico
Portata massima	Q	3700 kg
Altezza massima di sollevamento	h3	6.90 m
Sbraccio massimo		3.90 m
Sbraccio alla massima altezza		1 m
Forza di strappo con benna		6236 daN
Peso e dimensioni		
Peso a vuoto (con forche)		7650 kg
Altezza libera dal suolo	m4	0.41 m
Interasse	y	2.81 m
Lunghezza al portaforche (con gancio traino)	l11	4.97 m
Lunghezza al portaforche (senza gancio traino)	l3	4.80 m
Sbalzo anteriore		1.21 m
Larghezza	b1	2.39 m
Larghezza cabina	b4	0.95 m
Altezza	h17	2.38 m
Angolo di inclinazione in avanti	a5	134 °
Angolo di inclinazione verso l'alto	a4	12 °
Raggio di sterzata (esterno ruote)	Wa1	3.93 m
Modelli di pneumatici		Alliance - A580 - 460/70 R24 159A8
Ruote motrici (anteriori / posteriori)		2 / 2
Ruote direttrici (anteriori / posteriori)		2 / 2
Performance		
Sollevamento		6.80 s
Abbassamento		7.10 s
Uscita sfilo		5.80 s
Rientro sfilo		5.20 s
Inclinazione verso l'alto		3.20 s
Inclinazione verso il basso		2.80 s
Motore		
Marca motore		Deutz
Norma motore		Stage V
Modello motore		TCD 3.6 L4
Numero di cilindri - Cilindrata		4 - 3621 cm³
Potenza nominale motore (cv) / Potenza		129 cv / 95 kW
Coppia massima / Regime motore		500 Nm @1600 rpm
Forza di trazione		7800 daN
Dispositivo di pulizia automatica radiatori		Standard
Sistema di raffreddamento motore		4 radiatori (acqua + aria + olio idraulico + olio della trasmissione)
Convalidato HVO (secondo la norma EN 15940)		SI
Trasmissione		
Tipo di trasmissione		Convertitore di coppia
Cambio		Powershift
Numero di marce (avanti / indietro)		6 / 3
Velocità di trasferimento massima (la velocità può variare in funzione della normativa del paese)		40 km/h
Bloccaggio differenziale		Differenziale a slittamento limitato sull'asse anteriore
Freno stazionamento		Freno di stazionamento negativo automatico
Freno di servizio		Freni multidisco a bagno d'olio su assale anteriore e posteriore
Idraulico		
Tipo di pompa		Pompa a cilindrata variabile
Portata idraulica - Pressione idraulica		150 l/min - 270 bar
Distributore "flow sharing"		Standard
Capacità del serbatoio		
Capacità del serbatoio idraulico		135 l
Capacità del serbatoio del carburante		120 l
Liquido additivo diesel DEF (tipo AdBlue®)		10 l
Rumore e vibrazione		
Rumorosità al posto di guida (LpA) secondo la norma NF EN 12053		72 dB
Rumorosità nell'ambiente (LwA)		105 dB
Vibrazione sul gruppo complesso mani/braccia		< 2.50 m/s²
Varie		
Omologazione trattore		Omologazione trattore
Certificazione della cabina		Cabina ROPS - FOPS Livello 2
Comandi		JSM

tabella pneumatici opzionale

	Altezza	Larghezza
TRELLEBORG - TH400 - 460/70 R24 159A8	2.37 m	2.40 m
TRELLEBORG - TH400 - 500/70 R24 164A8	2.39 m	2.42 m
MICHELIN - XMCL - 500/70 R24 164A8	2.39 m	2.43 m
MICHELIN - BIBLOAD - 460/70 R24 159A8	2.37 m	2.40 m
MICHELIN - BIBLOAD - 500/70 R24 164A8	2.39 m	2.43 m
MICHELIN - XHA - 15.5 R25 158A2	2.37 m	2.40 m
NOKIAN - TRI STEEL - 460/65 R24 156A8	2.36 m	2.40 m
MICHELIN - XMCL - 460/70 R24 159A8	2.37 m	2.40 m
VREDESTEIN - ENDURION - 460/70 R24 159A8	2.38 m	2.41 m
VREDESTEIN - ENDURION - 500/70 R24 164A8	2.41 m	2.44 m
TRELLEBORG - TH500 - 460/70 R24 159A8	2.37 m	2.40 m
ALLIANCE - A585 - 460/70 R24 159A8	2.37 m	2.40 m

Opzioni / Livello finitura

S : Standard / O : Opzione / - : non disponibile

	Classic	Premium	Elite
Funzione di sollevamento			
Blocco idraulico dell'accessorio	O	O	O
Funzioni Idrauliche Intelligenti	O	O	O
L'impianto idraulico rigenerativo	O	O	O
Stazione operatore			
Allineamento automatico ruote	O	O	S
Autoradio bluetooth con microfono esterno (100 W)	O	O	S
Autoradio bluetooth con microfono integrato (100 W)	O	S	-
Climatizzazione con regolazione automatica	O	O	S
Climatizzazione manuale	O	S	-
Display "Harmony"	S	S	-
Display Vision 7"	O	O	S
Pacchetto Telecamera SafeView (x2)	O	O	O
Scomparto di stoccaggio dietro e sotto il sedile	O	O	O
Sedile in tessuto a sospensione pneumatica a bassa frequenza con riscaldamento - GRAMMER	O	O	O
Sedile in tessuto a sospensione pneumatica - GRAMMER	O	S	-
Sedile in tessuto con sospensione pneumatica a bassa frequenza - GRAMMER	O	O	S
Sedile in tessuto meccanico(Grammer)	S	-	-
Sospensione a sbalzo - "CRC attivo "	O	O	S
Specchio retrovisore esterno elettrico con sbrinamento	O	O	S
Telecamera HighView	O	O	O
Tergicristalli anteriore addizionale	O	S	S
Tuner autoradio (50 W)	S	-	-
Motorizzazione/Potenza			
Acceleratore manuale	O	O	S
Idraulica con portata continua	O	O	S
Funzioni secondarie			
Sistema di Ingrassaggio Automatico (AGS)	O	O	O
Luci			
Fari di lavoro posteriori a LED su cabina (X2)	O	S	S
Fari di lavoro su cabina	S	-	-
LED+ (4 fari di lavoro extra)	O	O	O
LED work lights on the boom (x2)	O	O	O
Luci di lavoro anteriori a LED sulla cabina (x2)	O	S	S
Luci stradali a LED anteriori	O	O	O

MLT 737-130 PS+ - Disegno quotato

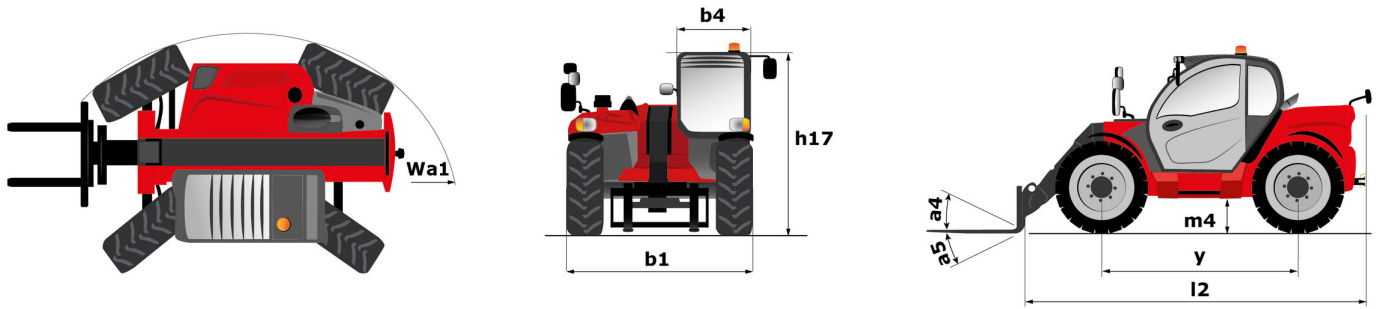

MLT 737-130 PS+ - Diagramma di carico

Macchina su pneumatici con forche

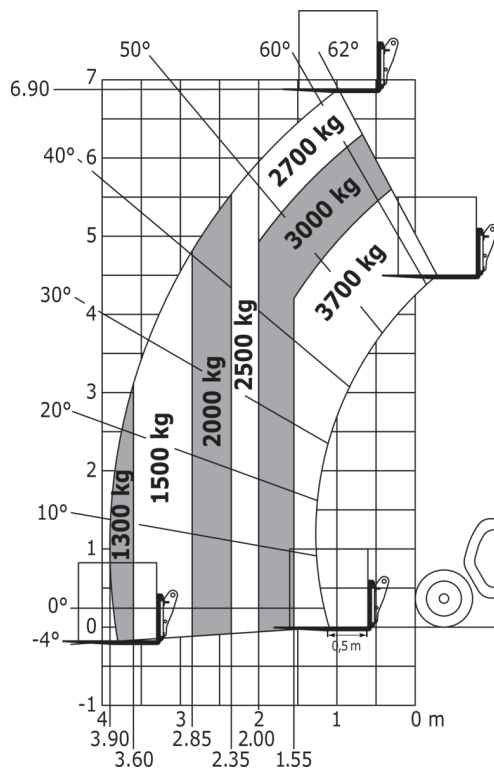



MANITOU

HANDLING YOUR WORLD

Sede centrale

MANITOU ITALIA Srl

Via Cristoforo Colombo 2, Loc. Cavazzona - 41013 CASTELFRANCO EMILIA (MO)

Tel: 059.95.98.11 - Fax 059.95.98.65

www.manitou.com



Questa pubblicazione presenta la descrizione delle versioni e delle possibilità di configurazione dei prodotti Manitou, che possono differire per attrezzature. Gli allestimenti presentati nel presente opuscolo possono essere di serie, optional o non disponibili, a seconda delle versioni. Manitou si riserva il diritto di modificare, in qualsiasi momento e senza alcun preavviso, le specifiche tecniche descritte e rappresentate. Le specifiche indicate non rappresentano alcun obbligo per il costruttore. Per maggiori dettagli, rivolgersi al proprio concessionario Manitou. Documento non contrattuale. Elenco delle specifiche non esaustivo. I loghi nonché l'identità visiva dell'azienda sono di proprietà di Manitou e non possono essere utilizzati senza autorizzazione. Tutti i diritti riservati. Le immagini e gli schemi contenuti nel presente opuscolo sono forniti esclusivamente a fini di consultazione e a titolo indicativo.

Manitou BF SA - Società anonima con consiglio di amministrazione. Capitale sociale: 39,668,399 euro - 857 802 508 RCS Nantes